

Ultra Low Cost Flight Path Recording for General Aviation and Legacy Aircraft

By Major Adam Cybanski

Major Adam Cybanski is the Deputy Promotion and Information at the Canadian Forces Directorate of Flight Safety in Ottawa, Canada. He is a tactical helicopter pilot with over 20 years and 2500 hours on fixed and rotary wing aircraft including the CT114 Tutor, CH139 Jet Ranger, CH135 Twin Huey and CH146 Griffon. He completed a tour in Haiti as Night Vision Goggle Specialist and Maintenance Test Pilot, and has managed the CH146 Griffon Full Flight Simulator. He is a graduate of the Aerospace Systems Course and holds a BSc in Computer Mathematics from Carleton University.

Flight data recorders have been a standard component of large aircraft for decades. Flight path recordings are critical for crash investigation, and are being increasingly used to improve flight training. Because of the size, weight, and cost of these flight recorders, most general aviation aircraft and many legacy aircraft fleets do not support this capability. Technology has provided new light-weight options for recording flight paths at a very low cost.

Flight Data Recorders

A Flight Data Recorder (FDR) is an electronic device that records aircraft parameters in flight. It is typically used not only for accident investigations but for tracking aircraft component life and wear and for monitoring operations as part of a flight operations quality assurance program (FOQA). These "Black Boxes" are comprised of a recording medium (photographic film, magnetic tape, solid-state memory), and connections to the aircraft sensors and systems. Completely integrating a FDR into a legacy aircraft can be complex and difficult, as any changes to an aircraft configuration necessitates airworthiness testing and certification.



Figure 1 – Traditional Flight Data Recorder

The Canadian Forces, like most other Air Forces, has a wide variety of FDR capabilities across the fleets. New aircraft such as the CC177 Globemaster and CH149 Cormorant are completely capable, recording hundreds of parameters each second. Most of the older aircraft record little, if anything. The CT114 Tutor, used by the Snowbirds Demonstration Team, only records vertical 'G' loading, while the CH124 Sea King records nothing at all, but has been retrofitted with a cockpit video recorder.

Canadian fighter aircraft are not equipped with standard FDRs, but can record critical flight parameters if their Head up Display system is set to record, or if they are carrying an Air Combat Maneuvering Instrumentation pod. The aircraft does employ a Maintenance Signal Data Recording System which saves some flight parameters at a lower sample rate. As a result, there is comprehensive flight data available in some incidents, but not others.

Some aircraft record basic parameters, such as airspeed and heading, but are missing other useful information such as GPS position. Without a doubt, FDR systems can improve safety, operational capability, and reduce life cycle costs. Notwithstanding, the implementation costs of a full-fledged integral FDR may be unaffordable. The CF has addressed this requirement by ensuring that all new aircraft

are fitted with full FDRs, and that there is a plan for alternate means of compliance for the legacy fleets. For many aircraft, such as the CT114 Tutor, CH-124 Sea King, and CH139 Jet Ranger, this means installation of an airborne image recording system.

For the purposes of visualization, a small subset of the FDR data is required. Specifically, latitude, longitude, altitude ASL, aircraft pitch, roll, and heading are needed to show the aircraft's flight path. With these six parameters, a useful visualization can be produced. Much more information is required to also convey the state of the aircraft throughout the sequence, but the movement of the aircraft in space is a good starting point for an investigation.

Visualization of flight path data is when the value of portable recorders truly can be seen. An accident flight can be played back from the cockpit perspective, or from a ground observer position. A marginal flight can be replayed over and over again, and compared to a "textbook" approach and landing. Flight path angle and visual references can be shown to pilots well before they go flying, so that there is an immediate sense of familiarity once they are in the air. We are just beginning to explore the ways that capturing flight path data can enhance safety and improve operational capability.

Technology has started providing effective alternatives for capturing these basic parameters (aircraft position and orientation). The two principle methods discussed in this paper are the employment of a portable Flight Path Recorder (FPR) to record sensor data, or the use of a video camera to record the flight, and subsequently analyze the footage to determine what the aircraft's flight path was. These inexpensive Flight Path Recorders and cameras do not replace an FDR, but can record critical information in the absence of one.

 CP-140 AURORA	✓	 CC-138 TWIN OTTER	✗
 CC-115 BUFFALO	✓	 CC-144 CHALLENGER	✓
 CT-142 DASH-8	✓	 CH-149 CORMORANT	✓
 CH-146 GRIFFON	✓ ✗	 CH-148 CYCLONE	✓
 CT-155 HAWK	✗	 CC-177 GLOBEMASTER III	✓
 CC-130J HERCULES	✓	 CT-156 HARVARD II	✓
 CF-188 HORNET	✗	 CC-130 HERCULES	✓
 CH-124 SEA KING	✗	 CH-139 JET RANGER	✗
 CT-114 TUTOR	✗	 CC-150 POLARIS	✓

Figure 2– RCAF Full FDR Capability

Flight Path Data

The modern FDR records aircraft parameters such as vertical acceleration, indicated airspeed, pressure altitude, aileron angle, rudder position, hydraulic pressure, engine RPMs, engine torque, fuel flows, autopilot selections, and much more information. This information is usually plotted graphically, although sometimes visualization can be employed to intuitively depict select parameters.

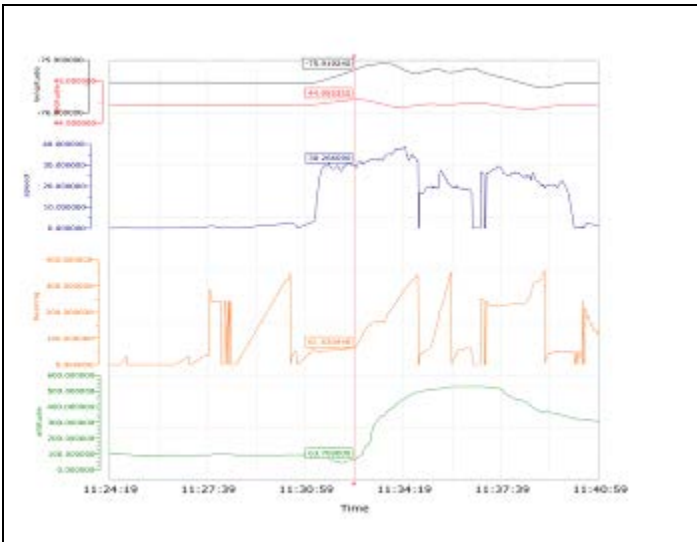

Figure 3 – Graphical Analysis of Data



Figure 4 – Visualization of Data

Flight Path Recording System

A portable FPR has three primary components: the sensors, a computer, and a battery. Sensors can include inertial accelerometers, magnetic compass, GPS, and camera. The computer collects the data from the numerous sensors, formats and integrates it, then saves the results, along with timing information into a memory chip or other medium such as micro-SD card. The battery powers everything.

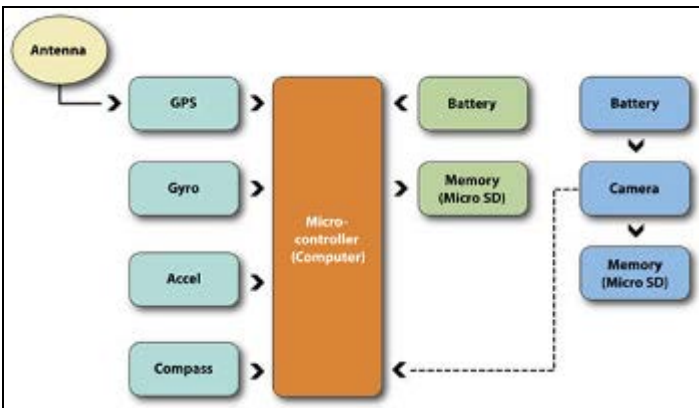

Figure 5 – Components of a Flight Path Recorder

The size and capability of the modern sensor is truly amazing. The ADXL345 digital accelerometer, (the small black chip at the bottom of the circuitboard in Figure 7), has a 10 bit resolution that can be configured to measure forces up to +/- 16 g. It can operate in a wide temperature

range (-40°C to +85°C), and can survive an impact up to 10,000 g. The device can measure far in excess of 100Hz, provided it is supported by the right hardware.

This type of Micro Electro Mechanical System employs a small inertial mass mounted on spring legs. When the force of gravity moves this mass, the capacitance between arms on the mass and stationary plates changes, which can be interpreted as a change in gravitational force. The component of gravity measured from three of these devices mounted orthogonally can be used to determine which way is down. Similar design can be employed to measure angular acceleration.

On a strap-down inertial system, the orientation of the sensors with respect to the aircraft body are known, thus it is easy to determine the pitch, roll, and heading. A portable system that is simply secured in a pocket has an unknown initial orientation: the sensor could be sideways, upside-down, or backwards. As a result, a post-flight calibration of the sensor must be conducted, so that readings noted when the aircraft is straight and level are subtracted from all subsequent readings. This can reveal the aircraft's true attitude, but as inertial sensors are prone to drift, they must be periodically corrected to maintain quality readings.

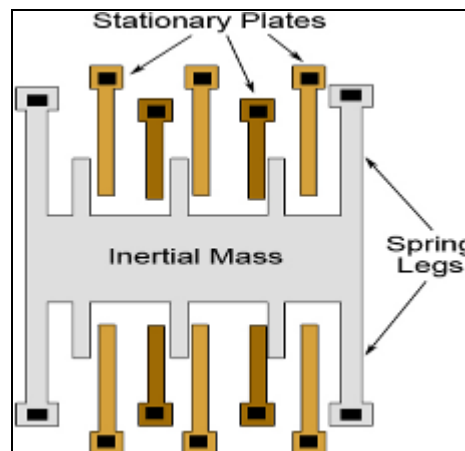

Figure 6 – MEMS Accelerometer

The devices seen in Figure 7, a 640x480 colour camera, a 10Hz GPS, a dual axis gyroscope/triple axis accelerometer IMU board, and a 2GB microSD card, all have very small form factors. The integration of these components into a single device, like the modern cell phone, tablet computer, or portable flight path recorder, can further reduce their size by eliminating substrates and interfaces.

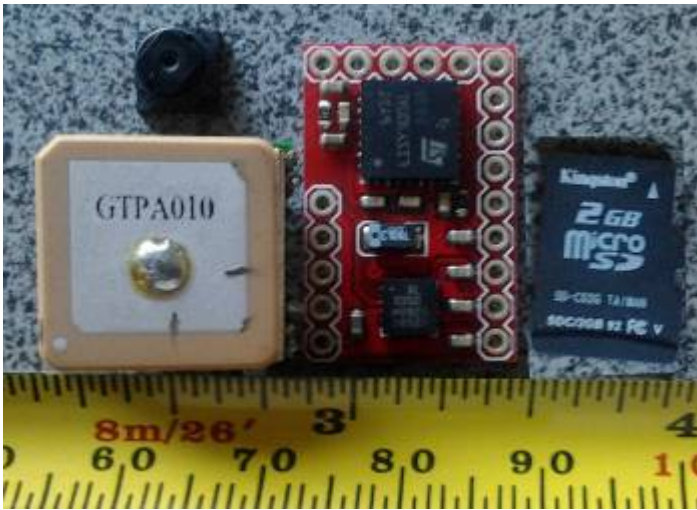

Figure 7 – Scale of Recorder Components

GPS data is relatively easy to employ. It provides Latitude, Longitude, and altitude at a reduced accuracy. Heading can be approximated by the aircraft track. GPS only provides an approximate position, at a low update rate. Accelerometers can provide very high resolution and high frequency data over a small area but are also susceptible to drift. Luckily, positional data from a GPS can be used to correct the accelerometer data over the long term. Specialized filters can fuse the data together into an integrated solution that is much more accurate than any of the individual components.

Dedicated Flight Recorders: Integrated Sensors

A prototype portable palmtop-based Flight Path Recorder was assembled at the Canadian Directorate of Flight Safety, and included sensors for attitude, altitude, and position as well as cockpit video (for validation of collected data). It was comprised of a small palmtop PC, tethered to a sensor package that included a GPS, altimeter, Inertial Movement Unit, and a USB video camera. The concept for employment was to carry the PC in a pocket and mount the sensors on the aircraft for a day VFR flight. The system would record aircraft position, altitude, attitude, as well as cockpit video. A project Airworthiness Clearance was granted to test the unit, classified as a Personal Electronic Device in gliders and tow planes.



Figure 8 – Portable FPR v1

Three versions of the portable FPR were made. Each was simpler and less expensive than the previous one. One of the limitations of the initial Portable FPR was the tether wire. The sensor package had to be secured to the aircraft with Velcro and a tie-wrap. This posed a threat as a projectile in event of a crash, and could be an obstacle to egress. The fragile connection between sensors and the recording device was vulnerable to disconnection, and caused a system failure on one occasion. Second and third, completely self-contained miniature FPRs were developed, assembled, and programmed. They consisted of a micro SD card-based recorder, an inertial navigation system, a 50 channel GPS, and a battery all in a small 4cm x 4cm package that could be secured in a pocket. It was supported by a 2cm x 7cm micro video camera, which could also be secured to a jacket, helmet, or inside a pocket.

The latest portable FPR is a Sparkfun Ultimate IMU, which has gyros and accelerometers in all directions, a 3-D magnetometer, a LPC2148 programmable microcontroller (miniature computer), and a micro SD socket to save the data to. Its functions are programmed in the C language, and uploaded from a PC through a mini-USB cable. The unit can save attitude and acceleration data at 30Hz. The GPS is a 66 channel GPS that runs at 10Hz, but only updates position at 2 Hz.



Figure 9 – Portable FPR v3

Trial

A Canadian Forces air cadet glider crashed in an orchard in Oliver, B.C. A visualization of the event was requested to help other cadets understand the event and prevent re-occurrence, but the aircraft was not equipped with an FDR.

In order to capture a sample glider approach profile for the visualization, a flight was conducted in Smith's Falls, ON in a similar glider equipped with the V3 portable FPR. The position, altitude, and aircraft orientation was recorded from a representative flight. The collected data was reviewed, then the entire flight path was repositioned and rotated to align with the runway and terminate at the crash location at Oliver, B.C. A visualization of the flight path in B.C. was produced, and found to be a useful visual aid when debriefing the accident.



Figure 10 – Flight Path Visualization

Several companies are starting to release portable FPRs with capabilities similar to the previously described FPR. Appereo Systems, LLC has a completely self-contained system that is hard mounted and draws power from the aircraft. Wi-Flight by the General Aviation Safety Network has a simple and intuitive portable system that can be carried in a pocket during flight, then automatically

synchronizes over the internet once on the ground, to provide playback of the flight through Google Earth on any internet computer. Kutta Consulting has a Personal FDR (PFDR) that employs gyros, accelerometers, and a GPS to capture flight data. As demand for these devices increases, more options should become available.

Adapted Flight Recorders: Ground-Based Image Recorders

Video cameras are everywhere today. They can be found in phones, tablets, iPod players, and other electronic devices. Most still cameras can produce good quality video. With all these sources, there is a good chance today that the terminal phase of an aircraft accident will be captured on video. Photogrammetric analysis of the video can reveal the aircraft's position, altitude, and orientation. Wise placement of good, high definition video cameras aimed at the approach and departure paths, represents an inexpensive way of capturing flight paths of aircraft in the most critical phase of flight.



Figure 11 – Modern Video Cameras

During investigation of an F18 incident at an airshow in Janesville, WI, visualization of the flight path was required. The Canadian CF18 is not equipped with an FDR, but does employ a maintenance recorder that captures flight parameters at a low resolution. A visualization was made using this data, but the results were not precise and looked unnatural. Luckily, the flight was filmed by an anonymous ground observer who posted the video on YouTube. For 188754, the location of the cameraman was determined first. This was done by triangulating the position using ground features visible during a 45 degree camera pan. Next, a rough flight plan for the aircraft was estimated by integrating INS data from the maintenance recorder, then shifting the path so that the lowest point in the path matched the button of the runway. A visualization

was produced from this path, from the perspective of the YouTube cameraman, and synchronized with the YouTube video.



Figure 12 - Original YouTube Imagery

The aircraft was seen to make a climbing turn immediately after passing the control tower in the visualization, but did so several seconds later in the YouTube video. In order to get the two to match, the entire flight path had to be moved 500 feet down the runway. This made sense from an operational perspective, as the pilot likely wanted the airshow crowd, located at the end of the runway, to better see the maneuvers, and so moved the approach point down the runway. Once a new visualization was produced using the repositioned flight path, the two videos looked much more similar.

The climbing turn in the visualization did not look natural. The YouTube video, at 30 frames per second, could potentially provide more detail on the aircraft position than the maintenance recorder could at one sample per second. The video was analyzed in Syntheyes. Trackers were put on the nose, tail, and wingtips of the aircraft. When any of these features were obscured, their likely location was calculated using cubic spline interpolation. An aircraft centroid was found by averaging these four points, and validated as a new tracker in the video.



Figure 13 - Aircraft Tracking

The runway stood in for the horizon. Trackers were placed at the left and right extents of the frame over the runway. The perpendicular distance of the aircraft centroid to the resulting horizon line was calculated, and using this data, along with the known aircraft distance and initial height above ground, a height profile for the aircraft was constructed. The data showed a smooth climb, which was used to improve the flight path for visualization. This video closely matched the original YouTube video.



Figure 14 - Final Flight Path Visualization

Adapted Flight Recorders: Airborne Image Recorders

High definition cameras are available in many electronic devices. They can also be purchased in the form of inexpensive "spy" cameras. These small devices can record full colour video at 20-30 frames per second onto a microSD card. If the video is focused out the window, preferably straight ahead, the video they record can be used to calculate the aircraft's flight path. Some units can

be configured to continuously record video, like an FDR.



Figure 15 – Portable Video Recorders

Trial

A drone carrying a high definition camera was flown in the local area. Photogrammetric analysis of measurable ground features in the video was used to calculate the aircraft position. Video trackers were placed on features that were easy to measure, such as driveway/road junctions, runway markers, corners of houses, prominent trees, etc. A file containing the three-dimensional location of these features in UTM, along with altitude in meters, was imported into the matchmoving software as survey data. The software then calculated the camera's location in space, as long as there were five features visible in each frame of video. The features needed to be spaced throughout each frame.

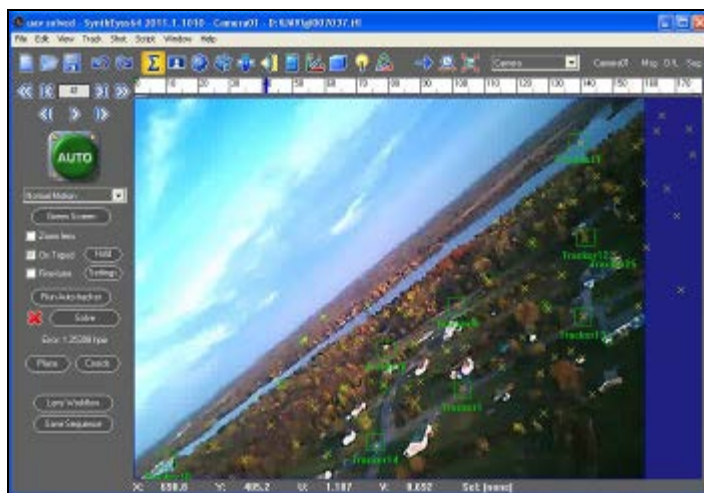

Figure 16 – Video Tracking

The data was subsequently smoothed, then a visualization

was produced at the same frame rate as the source video. Comparing the video and visualization showed when there were problems. When this happened, more trackers were added, or interpolation was conducted between validated camera positions. The original video was used to validate the derived flight path. The final visualization and the original video were found to match well, and showed that the data was a very good estimation of the actual flight path.



Figure 17 – Final Tracking Visualization

This method of flight path recording is inexpensive, and provides a useable product right away (a video from the camera perspective.) Photogrammetry of the video is difficult, but can be accomplished when required. It should be noted that accuracy of the photogrammetric calculations improve as the camera gets closer to the ground or identifiable objects. This is fortunate, as determining altitude at low levels is usually more critical than at high altitude.

Adapted Flight Recorders: Integrated Sensors

In the last few years, a very inexpensive device has become capable of recording flight paths. Modern cell phones and tablets are now armed with accelerometers, magnetometers, GPS, video cameras, and other sensors which can transform them into a very capable flight path recorder.

Many cell phones today are equipped with a decent GPS that can record position to an accuracy of 100m. They also use linear and angular accelerometers to orient the screen properly, no matter which way the device is held. Full three degree of freedom magnetometers allow the devices to point towards magnetic North, correcting with pitch and roll compensation.

There are applications freely available on the internet for Android and IOS operating systems that allow you to log this sensor data at a fairly high rate. These applications, such as Sensor Track, Sensor Logger and GPSLogger save the data into the device memory, or onto a microSD card. The GPS data can be saved in GPX and KML format, so that the flight can be reviewed in Google Earth.



Figure 18 – Cell Phone Flight Recording

Two flights were recorded on an inexpensive, low-end cell phone (Samsung Gio GT-S5660M running Android 2.3.4). One flight was conducted using a drone flying around the local neighborhood, and another in an Airbus A320 on an international commercial flight. The phone was put into “Flight” mode, which eliminates any electromagnetic emissions.

In the drone trial, the linear accelerometers froze once engines were brought above idle. The model of phone used does not incorporate angular accelerometers, leaving the phone with only GPS and an impaired magnetometer. Even with these limitations, the promise of this technology was evident.

Flight path video and accompanying GPS data was recorded during the drone flight. Following the flight, the GPS information was superimposed over the video. The entire GPS track was depicted in a top-down view, with a red dot to show current position, and horizontal and vertical bars to graphically show groundspeed and altitude respectively. The GPS data correlated well with the flight video.



Figure 19 – Data Synchronized with Video

Data from the airliner flight was imported into Google Earth in two ways. The raw GPX file was able to show the 1 Hz GPS locations from taxi out to taxi in. The position drifted in a few spots, but it was easy to discern the taxiing sequence, the flight routing, and even which side of the plane the recording was taken from (right window). The elevation data was not as reliable as the position, and appeared stepped and problematic in the departure and approach /landing phases.

Playing back the KML file as a tour produced a flight simulation type of effect. The view from the flight path could be slewed left, right, up or down. There was a slider to scroll through the flight, and changes in heading were shown by simulated bank of the view. If higher fidelity altitude information were available for the takeoff and

approach, this system would be a very capable flight debrief system.

the horizon. It must be even closer to estimate distance or aircraft attitude. As a result, careful camera location planning is required to take advantage of this method.

An airborne camera has the advantage of having the aircraft's viewpoint. As long as the horizon can be discerned, roll and pitch attitudes can be calculated quite accurately. Aircraft location, altitude, and heading require that several identifiable ground features be visible in each frame of video. The calculation of these parameters can be difficult and time-consuming. Video flight path recording has the advantage that the recorded images are useful as they are without visualization, for qualitative analysis of the flight.

The adapted FPR is becoming a powerful solution for recording position and orientation parameters. Cell phones and tablets have different capabilities, depending on the model and generation, but their utility for recording flight should not be discounted. Capability to record and analyze flight data on a small handheld device might be the most inexpensive and versatile solution for legacy fleets and general aviation in the future.

The dedicated FPR represents the most reliable solution. These purpose-built devices are specifically designed to capture flight parameters, and they do so relatively better than any other method described here. Certified, commercial portable FPRs represent the best choice when a full FDR is beyond the means of an operator.

Conclusion

Some of the Flight Path parameters of a traditional Flight Recorder can now be procured at a very low cost. Basic components of sensors, battery, and computer are even resident on most phones sold today, and the capabilities of future portable FPRs promise to increase, while costs decrease. Portable FPRs can provide benefits to flight safety investigations by revealing how an aircraft was flown prior to an accident, and can enhance operational capability by providing a flight debrief system for aircrew under training. These types of capabilities are being considered by the Royal Canadian Air Force in order to address deficiencies in Flight Data Recording for our legacy fleets. Comprehensive FDRs are still preferred, but ultra low cost flight path recorders are better than no recorder at all.

For a ground-based camera, the distance from the aircraft to the camera is the limiting factor. The aircraft must be quite close in order to discern the location where it is above

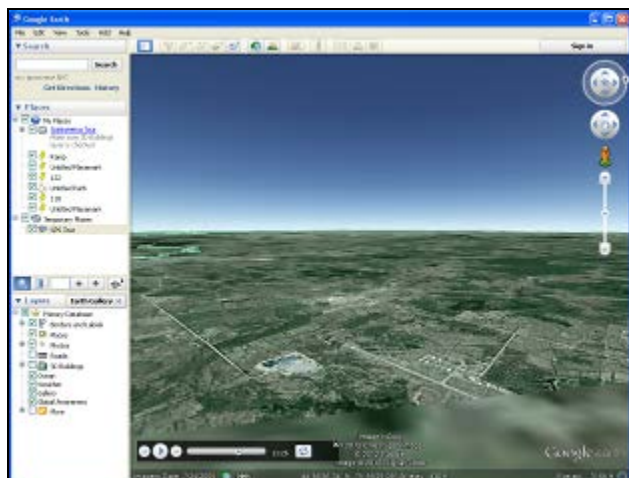

Figure 20 – Google Earth Visualization

Comparisons

Four methods of flight path recording were discussed in this paper: dedicated flight path recorders, adapted flight path recorders, onboard video, and ground-based video. The costs of these systems can vary greatly, depending on the specific equipment and configuration. An aircraft certified portable FPR or commercial video recording systems for an airport can cost thousands or even tens of thousands of dollars, but at the other end of the spectrum, a cell phone can record flight path and replay the flight on Google Earth for free. The estimated costs for the systems used in this paper, and the relative capabilities are indicated below.

	Gnd Camera	Airborne Camera	Adapted FPR	Dedicated FPR	Airborne Camera
Cost	\$0	\$50	\$125	\$500	\$50
Position Resolution	L	M	M	H	M
Attitude Resolution	L	M	L	H	M